

ZOO-01D

BALANCÍN DE MUELLES "EL CONEJO"
SEESAW-SPRINGER "THE RABBIT"
JEU À RESSORT "LE LAPIN"

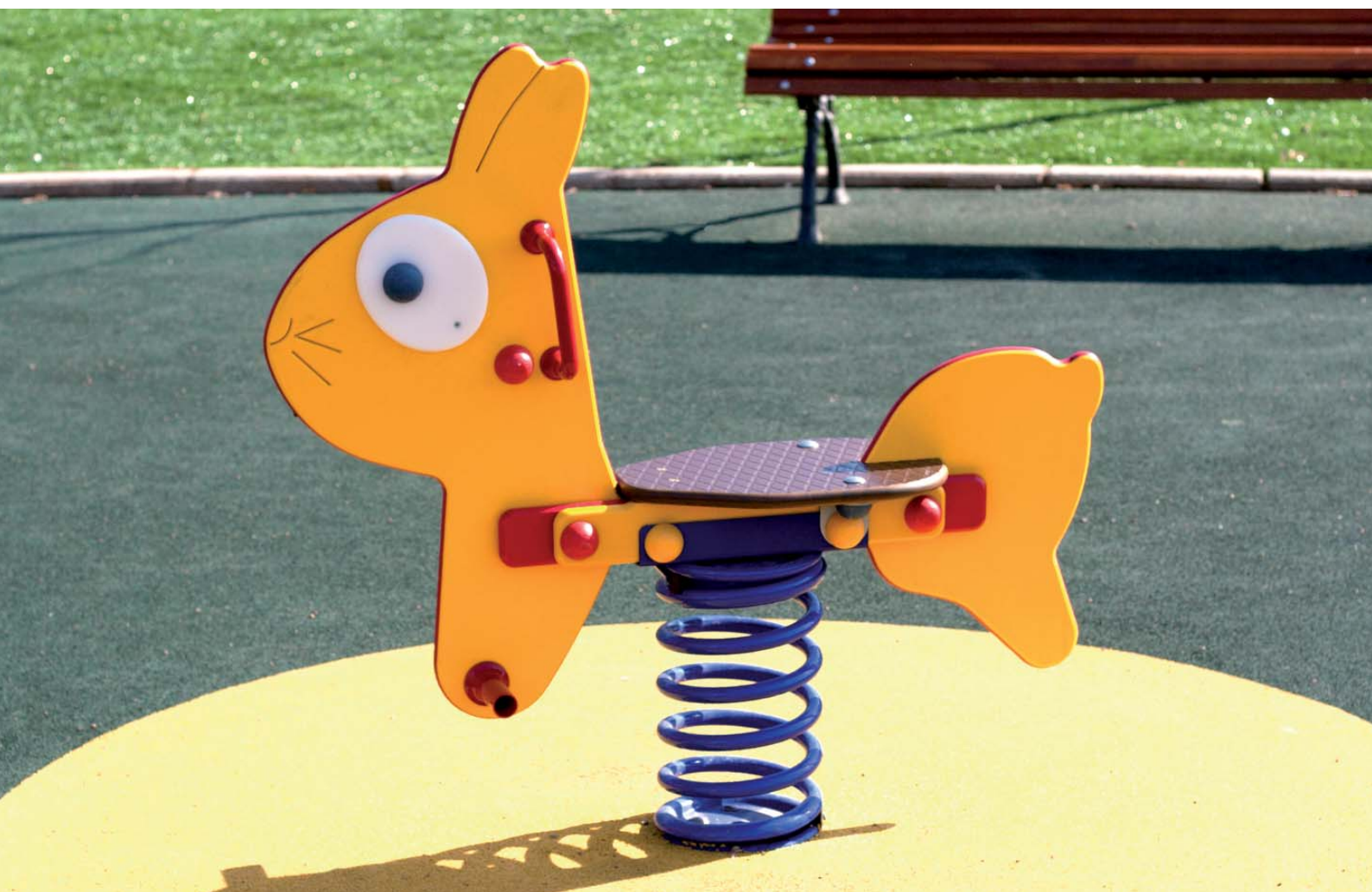

ZOOPARK®



PREMIO AFAMOUR
AL DISEÑO 2010

ASOCIACIÓN ESPAÑOLA DE FABRICANTES
DE MOBILIARIO URBANO Y PARQUES INFANTILES

Características

Characteristics

Caractéristiques



EN 1176



+ 1 año



1 u.



101 x 25 x 96 cm.



43 cm.



7,68 m²

Instalación del equipo

Installation of the equipment

Installation de l'équipement



1 p



1 h

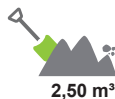

2,50 m³

* Estructura

Structure

Structure

Acero pintado en polvo de poliéster

Powder-coated steel

Acier peint en poudre de polyester

* Paneles

Panels

Panneaux

HDPE (Polietileno de alta densidad) de 13 y 19 mm.

HDPE (High-density polyethylene) 13 and 19 mm.

PEHD (Polyéthylène de haute densité) 13 et 19 mm.

* Asiento

Seat

Siège

Contrachapado fenólico antideslizante / HPL antideslizante

Phenolic non-slip plywood / non-slip HPL

Contreplaqué phénolique antidérapant / HPL antidérapant

mobipark ESPAÑA
Pol. Ind. Cantavella Calle Lliria, 8
46135 Albalat dels Sorells (Valencia) Spain

T. +34 96 149 45 12
F. +34 96 149 46 02

mobipark@mobipark.com
www.mobipark.com

PARQUES INFANTILES MOBILIARIO URBANO

es

Balancín de muelle de tamaño extra grande con figura de conejo (largo: 101cm). Diseño de la figura realizado por medio de formas, grabados mecanizados y paneles superpuestos.

Garantiza una seguridad completa al niño gracias al muelle anti-pinzamiento. Debido al diseño, el juego aporta una gran estabilidad durante la acción a la vez que permite el balanceo en todas las direcciones.

en

Rabbit-shaped seesaw springer of especially big size (length rabbit: 101cm). The animal's design is realized with shape, mechanised engravings and superimposed panels.

Its non-twining spring guarantees complete safety for the children. Although it allows seesawing in all directions, its design makes it very stable in its movement.

fr

Jeu à ressort de taille extra grande avec figurine de lapin (longueur: 101cm). Le design du animal se réalise au moyen des formes, des gravures mécanisées et des panneaux superposés.

Garantie une sécurité complète grâce au ressort anti-pincement. Son design apporte une grande stabilité en activité, tout en permettant un balancement dans tous les sens.

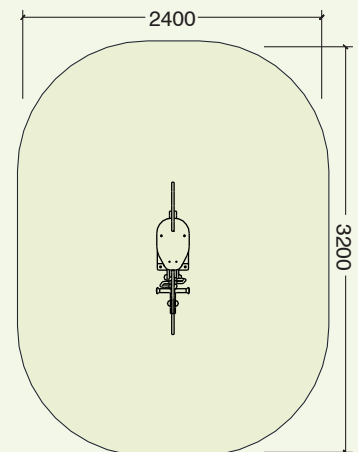
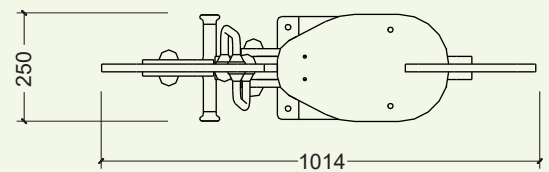
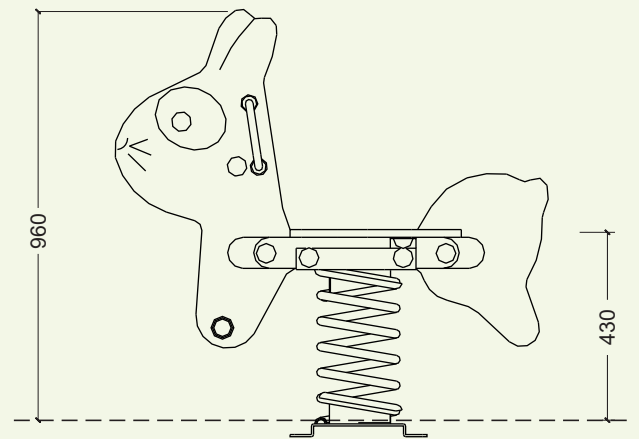

mm.



BALANCÍN DE MUELLES "EL CONEJO"
SEESAW-SPRINGER "THE RABBIT"
JEU À RESSORT "LE LAPIN"