

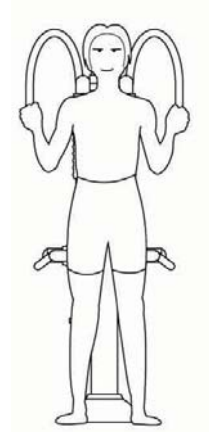

MÚSCULOS EJERCITADOS
TRAINED MUSCLES
MUSCLES ENTRAÎNÉS



EJECUCION
EXECUTION
EXÉCUTION



Certificado EN-16630:2015
EN-16630:2015 Certificate
Certifié EN-16630:2015



Uso recomendado para jóvenes y adultos o usuarios a partir de una estatura de 1400mm.
Use recommended for youths and adults or users with stature over 1400mm.
Utilisation recommandée pour jeunes et adults ou usagers avec taille supérieure de 1400mm.

139 x 74 x 149 cm.

0 cm.

3,52 m²

- | | |
|---|--|
| * Estructura
Structure
Structure | Acero cincado y doble capa de pintura electroestática al horno
Steel, zinc-plated and double layer of powder-coating, oven cured
Acier zingué et double revêtement par poudre, séché au four |
| * Cilindros
Cylinders
Cylindres | ABS para uso exterior
ABS for outdoor use
ABS pour l'usage à l'extérieur |
| * Embellecedor base
Anchor coverage
Couverture d'ancrage | Aluminio
Aluminium
Aluminium |
| * Tornillería
Screws
Visserie | Acero inoxidable y galvanizado
Stainless and galvanised steel
Acier inoxydable et galvanisé |

es

Elemento de entrenamiento al aire libre, fabricado con estructura en acero cincado con acabado de doble capa de pintura electroestática al horno. Poste principal de tubo de acero Ø140x3mm. Barras de masaje de tubo Ø60x2,75mm.

Elemento para instalación hormigonada conforme a la norma EN16630, ideal para gimnasios urbanos en parques públicos.

FUNCIÓN: Relaja la tensión de cadera y espalda. Ayuda a mejorar la circulación del sistema nervioso.

USO: Coloque su espalda sobre la columna de masaje y realice un movimiento lento vertical u horizontal.

PRECAUCIÓN: Se trata de un movimiento de relajación por lo que no hay que apretar excesivamente la espalda contra los cilindros.

en

Outdoor training element made of structure of zinc-plated steel with double layer of powder-coating oven-cured. Central post of steel tube Ø140x3mm. Massage bars of steel tube Ø60x2,75mm.

Element for concrete installation according to EN16630. Perfect for urban gyms at public parks.

FUNCTION: Relaxes tenseness of hips and back. Helps to improve the circulation the nervous system.

USE: Stand upright with your back to the massage column and realise slowly vertical or horizontal movements.

PRECAUTION: It is to be a relaxation exercise. For this reason do no press your back excessively against the cylinders.

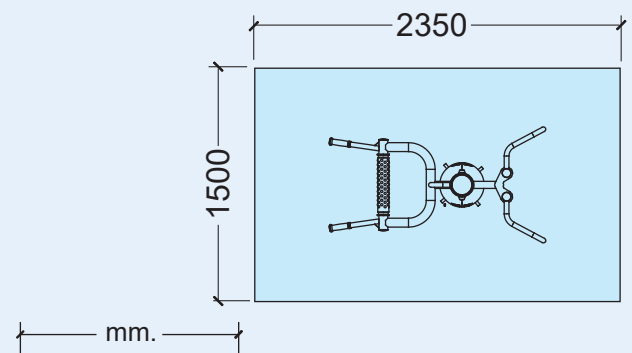
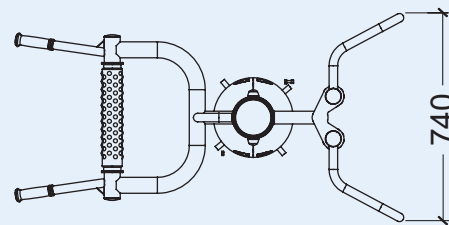
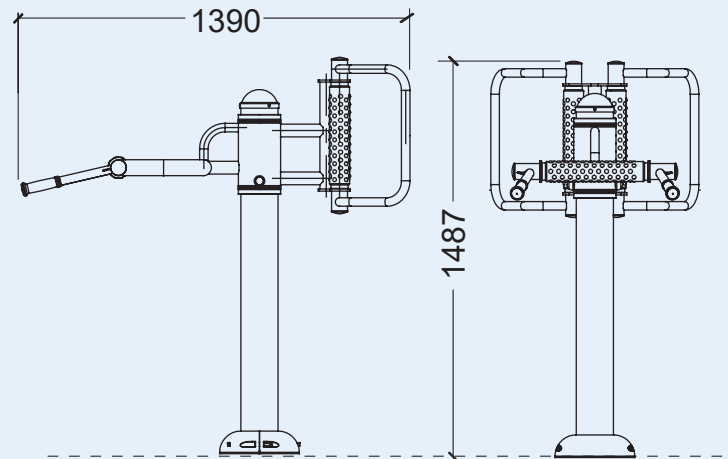

**MASAJE
MASSAGE
MASSAGE**