

JOC-62-08

JUEGO PANEL ABACO
ACTIVITY PANEL "COUNTING FRAME"
PANNEAU ABAQUE



Características

Characteristics

Caractéristiques



EN 1176



+ 1 año



Nº 2 u.

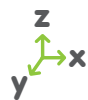

80 x 9,5 x 137 cm.



0 cm.



12 m²

Instalación del equipo

Installation of the equipment

Installation de l'équipement



1 p



1 h



3,90 m³

* Estructura

Structure

Structure

Madera laminada de pino de Suecia tratada

Laminated Swedish pinewood autoclave

Bois lamellé de pin suédois traité en autoclave

* Barras

Bars

Barres

Acero Inoxidable

Stainless Steel

Acier Inoxydable

* Discos

Discs

Disques

Polietileno

Polyethylene

Polyéthylène



mobipark ESPAÑA
Pol Ind. Cantavella Calle Lliria, 8
46135 Albalat dels Sorells (Valencia) Spain

T. +34 96 149 45 12
F. +34 96 149 46 02

mobipark@mobipark.com
www.mobipark.com

mobipark
PARQUES INFANTILES MOBILIARIO URBANO

es

Panel de juego que simula un ábaco de colores.
El ábaco está formado por 5 barras dispuestas en 5 filas que contienen los diferentes coloridos discos que componen el ábaco. Cada barra contiene 10 discos, para mejor manejo 5 en un color y 5 en otro color.

Los postes de 95x95x1300mm están fabricados con madera laminada tratada en autoclave vacío-presión-vacío, nivel IV, contra carcoma, termitas e insectos y posteriormente pintado con lasur. Tornillería fabricada en acero galvanizado oculta mediante tapones de nylon que impiden su manipulación por parte de los usuarios.

en

Activity panel which represents a colourful counting frame.

The counting frame is composed of 5 bars arranged in 5 lines which contain each of the bars 10 colourful discs that form the counting frame. For easier handling 5 of the 10 disc of each line are in one colour and 5 in another colour.

The posts of 95x95x1300mm are made of laminated wood treated with autoclave vacuum-pressure impregnation, level IV, against woodworm, termites and insects and afterwards painted with glaze. The screws are made of galvanized steel and hidden by nylon coverings which prevent their manipulation by users.

fr

Panneau de jeu qui simule un abaque de couleurs.
L'abaque est formé par 5 barres disposées en 5 files qui comportent différents disques qui composent le boulier. Chaque barre se compose de 10 disques, - 5 d'une couleur, 5 d'autre couleur.

Les poteaux de 95x95x1300 mm sont fabriqués avec du bois laminé traité en autoclave sous vide-pression-vide, niveau IV, contre les vrillettes, termites et insectes et peint par la suite avec du lasure. Visserie fabriqué en acier galvanisé cachée par des capuchons en nylon qui empêchent leurs manipulation par les utilisateurs.

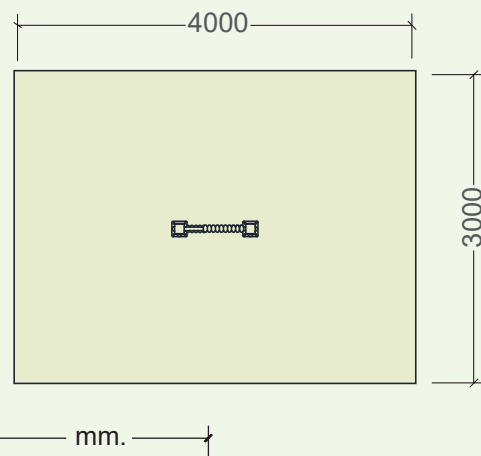
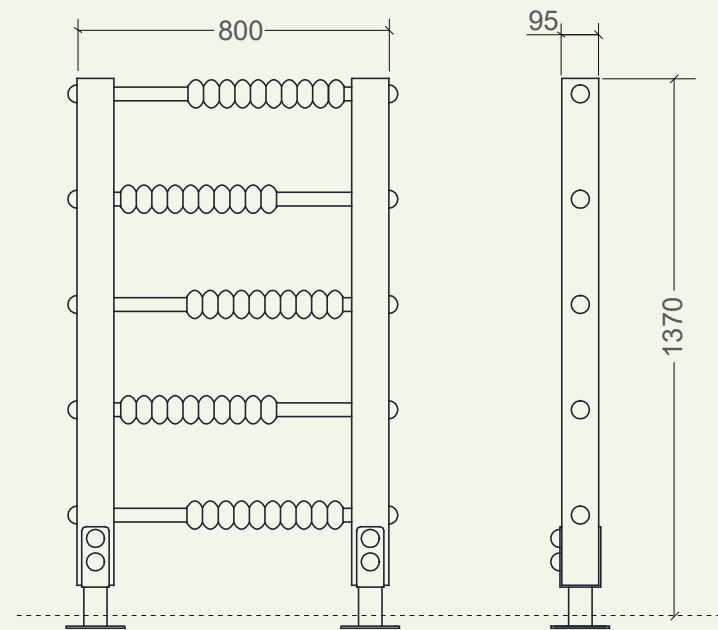

JUEGO PANEL ABACO
ACTIVITY PANEL "COUNTING FRAME"
PANNEAU ABAQUE

