



## Características

Characteristics

Caractéristiques



EN 1176



+ 1 año



2 u.



100 x 11,3 x 141 cm.



0 cm.



12 m<sup>2</sup>

## Instalación del equipo

Installation of the equipment

Installation de l'équipement

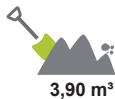

\* **Estructura** Madera laminada de pino de Suecia tratada en autoclave  
Structure Laminated Swedish pinewood autoclave treated  
Structure Bois lamellé de pin suédois traité en autoclave

\* **Panel** HDPE (Polietileno de alta densidad) de 19 mm.  
Panel HDPE (High-density polyethylene) 19 mm.  
Panneau PEHD (Polyéthylène de haute densité) 19 mm.

es

Panel de juego que simula una escotilla, por la que los niños pueden atravesar de lado a lado y que da mucho juego a la imaginación.

El panel está fabricado en polietileno de alta densidad (HDPE) Play Tech de 19mm de espesor, anti-vandálico, resistente a los grafitis, de fácil limpieza y con protección UV. Los postes de 95x95x1300mm están fabricados con madera laminada tratada en autoclave vacío-presión-vacío, nivel IV, contra carcoma, termitas e insectos y posteriormente pintado con lasur.

Tornillería fabricada en acero galvanizado oculta mediante tapones de nylon que impiden su manipulación por parte de los usuarios.

en

Activity panel which represents a porthole, through which the children can pass from one side to the other and which give a lot of space for imagination.

The panel is made of Play Tech high density polyethylene (HDPE) with thickness 19mm, anti-vandal, graffiti resistant, easy to clean and UV resistant. The posts of 95x95x1300mm are made of laminated wood treated with autoclave vacuum-pressure impregnation, level IV, against woodworm, termites and insects and afterwards painted with glaze.

The screws are made of galvanized steel and hidden by nylon coverings which prevent their manipulation by users.

fr

Panneau de jeu qui simule une écoutille, par laquelle les enfants peuvent traverser d'un côté à l'autre côté et qui donne beaucoup d'espace pour l'imagination.

Le panneau est fabriqué en polyéthylène de haute densité (PEHD) Play tech de 19mm d'épaisseur, antivandalisme, résistant aux graffitis, facile à nettoyer et avec protection UV. Les poteaux de 95x95x1300mm sont fabriqués avec du bois laminé traité en autoclave sous vide-pression-vide, niveau IV, contre les vrillettes, termites et insectes et peint par la suite avec du lasure.

Visserie fabriqué en acier galvanisé cachée par des capuchons en nylon qui empêchent leurs manipulation par les utilisateurs.

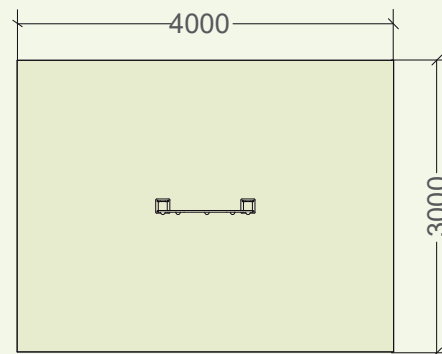
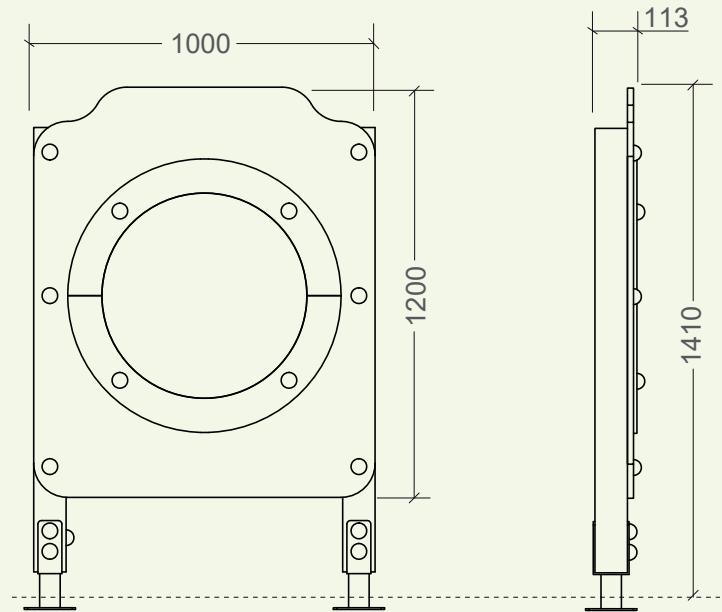

mm.



**JUEGO PANEL ESCOTILLA**  
**ACTIVITY PANEL "PORTHOLE"**  
**PANNEAU ÉCOUTILLE**

