

PIPE CLIPS

PINZAS

PP. 20. OP - PP PIPE CLIP

PP open pipe clip
• Metric series

Pinza abierta en PP
• Serie métrica

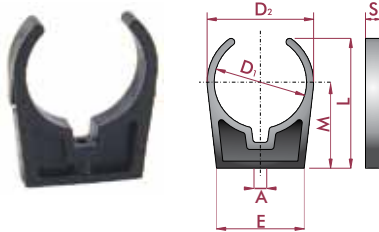

D ₁	REF.	CODE
20	11 20 020	02132
25	11 20 025	02133
32	11 20 032	02134
40	11 20 040	02135
50	11 20 050	02136
63	11 20 063	02137
75	11 20 075	02138
90	11 20 090	02139
110	11 20 110	08908
125	11 20 125	08909
140	11 20 140	10955
160	11 20 160	08910
200	11 20 200	08911
225	11 20 225	10957

L	S	E	D ₂	M	A
38	12	19	26	29	5,5
44	13	23	32	34	5,5
53	14	30	39	40	5,5
60	15	37	48	44	5,5
70	16	49	61	51	6,4
86	17	62	76	62	6,4
108	20	75	87	75	6,75
130	24	89	106	98	6,75
139	24	107	127	90	8,5
153	26	121	143	97	8,5
167	28	195	164	113	8,5
181	28	225	182	122	8,5
215	31	265	228	142	8,5
256	36	318	263	171	10,5

PP. 20. CL - PP PIPE CLIP

PP closed pipe clip
• Metric series

Pinza con cierre en PP
• Serie métrica

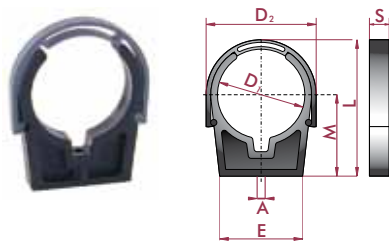

D ₁	REF.	CODE
50	11 20 450	02140
63	11 20 463	02141
75	11 20 475	02142
90	11 20 490	02143
110	11 20 510	08916
125	11 20 525	08917
140	11 20 540	10956
160	11 20 560	08918
200	11 20 599	08919
225	11 20 425	10958

L	S	E	D ₂	M	A
84	16	49	68	51	6,4
103	17	62	84	62	6,4
129	20	75	107	75	6,75
152	24	89	118	91	6,75
161	24	107	143	90	8,5
181	26	121	156	97	8,5
201	28	195	176	113	8,5
216	28	225	196	122	8,5
256	31	265	243	142	8,5
306	36	318	278	171	10,5

PP. 20. CP - PP PIPE CLIP

PP bridle clamp
• Metric series

Pestillo pinza en PP
• Serie métrica

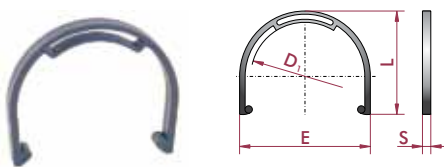

D ₁	REF.	CODE
50	11 20 650	02144
63	11 20 663	02145
75	11 20 675	02146
90	11 20 690	02147
110	11 20 710	08912
125	11 20 725	08913
140	11 20 740	11300
160	11 20 760	08914
200	11 20 799	08915
225	11 20 625	11301

L	S	E
55	8	68
68	10	84
81	11	100
95	13	118
110	14	139
121	15	157
130	17	176
147	17	195
171	19	237
182	23	277

ASSEMBLY

Pipe clips spacing

Thermoplastic pipes need to be supported at certain intervals, which depend on several factors: material, temperature, density of the medium transported and pipe density. The following table summarizes the recommended spacing between pipe clips.

The values given in the tables are intended primarily as a guide.

MONTAJE

Espaciado de las pinzas

Las tuberías termoplásticas necesitan ser apoyadas cada ciertos intervalos, en función de varios factores: material, temperatura, densidad del medio transportado y densidad de la tubería. La tabla siguiente resume el espaciado recomendado entre las pinzas de fijación.

Los valores en las tablas son indicativos y deben ser utilizados como referencia.

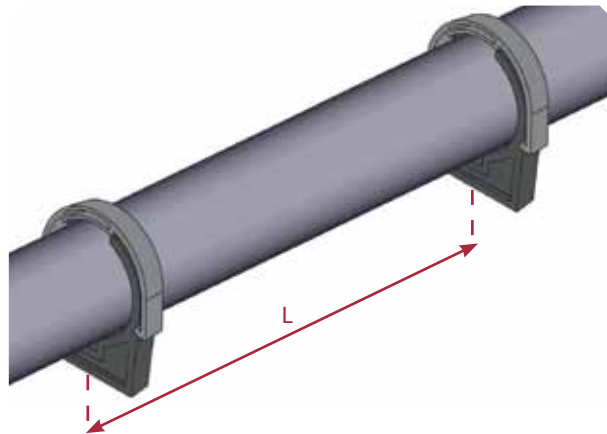

Material Pipe outside diameter D (mm)	Recommended L value in cm for PVC-U (PN 16) pipes			Recommended L value in cm for PE (SDR 11) pipes		
	≤ 20°C	40°C	60°C	≤ 20°C	40°C	60°C
20	115	105	75	55	50	40
25	125	110	80	65	55	50
32	140	130	95	75	65	55
40	150	140	105	90	75	65
50	170	160	120	105	90	75
63	190	180	135	120	105	90
75	210	195	150	135	120	100
90	230	210	165	150	135	115
110	250	235	185	165	150	130
125	270	250	195	175	160	140
140	285	265	205	190	175	150
160	305	285	220	205	185	160
200	340	315	245	230	210	190
225	360	335	265	245	225	205

For PVC-U PN 10 pipes, multiply the values given in the table by 0,95

For PE SDR 17 pipes, multiply the values given in the table by 0,90